

# 2-WIRE TRANSMITTER WITH HART® PROTOCOL



- RTD, TC, Ohm, or mV input
- Extremely high measurement accuracy
- HART® communication
- Galvanic isolation
- For DIN form B sensor head mounting



### Application:

- Linearised temperature measurement with Pt100...Pt1000, Ni100...Ni1000, or TC sensor.
- Difference or average temperature measurement of 2 resistance or TC sensors.
- Conversion of linear resistance variation to a standard analogue current signal, for instance from valves or Ohmic level sensors.
- Amplification of a bipolar mV signal to a standard 4...20 mA current signal.
- Connection of up to 15 transmitters to a digital 2-wire signal with HART® communication.

### Technical characteristics:

- Within a few seconds the user can program PR5335A to measure temperatures within all ranges defined by the norms.
- The RTD and resistance inputs have cable compensation for 2-, 3- and 4-wire connection.
- The 5335A has been designed according to strict safety requirements and is thus suitable for application in SIL 2 installations.
- Continuous check of vital stored data for safety reasons.
- Sensor error detection according to the guidelines in NAMUR NE 89.

### Mounting / installation:

- For DIN form B sensor head or DIN rail mounting with the PR fitting type 8421.

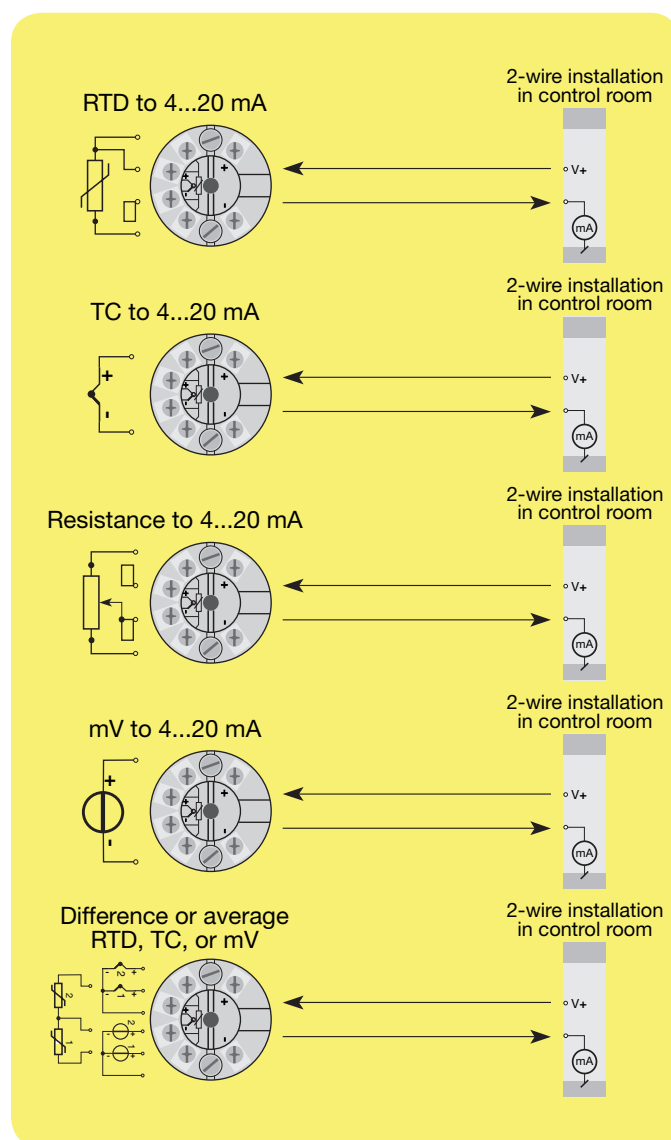

Order: 5335A

Type
5335A

**Connections:**

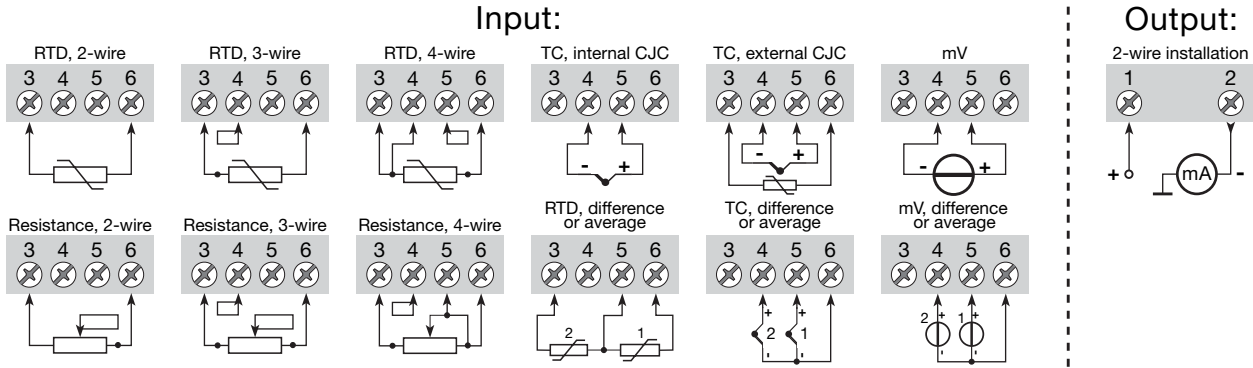

**Electrical specifications:**

**Specifications range:**

-40°C to +85°C

**Common specifications:**

- Supply voltage, DC ..... 8.0...35 V
- Voltage drop ..... 8.0 VDC
- Isolation voltage, test / operation ..... 1.5 kVAC / 50 VAC
- Communications interface ..... Loop Link & HART®
- Signal / noise ratio ..... Min. 60 dB
- Signal dynamics, input ..... 22 bit
- Signal dynamics, output ..... 16 bit
- Calibration temperature ..... 20...28°C
- Accuracy, the greater of general and basic values:

- Cable resistance per wire (max.) ..... 5 Ω
- Sensor current ..... Nom. 0.2 mA

**TC input:**

Type	Min. temperature	Max. temperature	Min. span	Standard
B	+400°C	+1820°C	100°C	IEC584
E	-100°C	+1000°C	50°C	IEC584
J	-100°C	+1200°C	50°C	IEC584
K	-180°C	+1372°C	50°C	IEC584
L	-100°C	+900°C	50°C	DIN 43710
N	-180°C	+1300°C	50°C	IEC584
R	-50°C	+1760°C	100°C	IEC584
S	-50°C	+1760°C	100°C	IEC584
T	-200°C	+400°C	50°C	IEC584
U	-200°C	+600°C	50°C	DIN 43710
W3	0°C	+2300°C	100°C	ASTM E988-90
W5	0°C	+2300°C	100°C	ASTM E988-90

General values		
Input type	Absolute accuracy	Temperature coefficient
All	≤ ±0.05% of span	≤ ±0.005% of span / °C

Basic values		
Input type	Basic accuracy	Temperature coefficient
Pt100 and Pt1000	≤ ±0.1°C	≤ ±0.005°C/°C
Ni100	≤ ±0.2°C	≤ ±0.005°C/°C
Lin.R	≤ ±0.1 Ω	≤ ±5 mΩ/°C
Volt	≤ ±10 μV	≤ ±0.5 μV/°C
TC type: E, J, K, L, N, T, U	≤ ±0.5°C	≤ ±0.025°C/°C
TC type: B, R, S, W3, W5	≤ ±1°C	≤ ±0.1°C/°C

EMC immunity influence ..... < ±0.1% of span  
 Extended EMC immunity:  
 NAMUR NE 21, A criterion, burst ..... < ±1% of span

- Vibration ..... IEC 60068-2-6 Test FC
- Lloyd's specification no. 1 ..... 4 g / 2...100 Hz
- Humidity ..... < 95% RH (non-cond.)
- Dimensions ..... Ø 44 x 20.2 mm
- Protection degree (encl. / terminal) ... IP68 / IP00

**Electrical specifications, input:**

Max. offset ..... 50% of selec. max. value

**RTD and linear resistance input:**

RTD type	Min. value	Max. values	Min. span	Standard
Pt100	-200°C	+850°C	10°C	IEC 60751
Ni100	-60°C	+250°C	10°C	DIN 43760
Lin. R	0 Ω	7000 Ω	25 Ω	-----

Cold junction compensation ..... < ±1.0°C

**Voltage input:**

- Measurement range ..... -800...+800 mV
- Min. span ..... 2.5 mV
- Input resistance ..... 10 MΩ

**Current output:**

- Signal range ..... 4...20 mA
- Min. signal range ..... 16 mA
- Updating time ..... 440 ms
- Load resistance ..... ≤ (V<sub>supply</sub> - 8) / 0.023 [Ω]

**Sensor error detection:**

Programmable ..... 3.5...23 mA

**Ex approval:**

KEMA 03ATEX1508 X ..... II 3 GD  
 EEx nA [L] II C T4 or T6

**Marine approval:**

Det Norske Veritas, Ships & Offshore.. Stand. for Certific. No. 2.4

**GOST R approval:**

VNIIM, Cert. No. .... Ross DK.ME48.V01899

**Observed authority requirements: Standard:**

- EMC 2004/108/EC
- Emission and immunity ..... EN 61326
- ATEX 94/9/EC ..... EN 60079-15

**Of span =** Of the presently selected range

