

2-WIRE PROGRAMMABLE TRANSMITTER



- RTD, TC, Ohm, or mV input
- Extremely high measurement accuracy
- 1.5 kVAC galvanic isolation
- Programmable sensor error value
- For DIN form B sensor head mounting



Application:

- Linearised temperature measurement with Pt100...Pt1000, Ni100...Ni1000, or TC sensor.
- Conversion of linear resistance variation to a standard analogue current signal, for instance from valves or Ohmic level sensors.
- Amplification of a bipolar mV signal to a standard 4...20 mA current signal.

Technical characteristics:

- Within a few seconds the user can program PR5331B, C & D to measure temperatures within all ranges defined by the norms.
- The RTD and resistance inputs have cable compensation for 2-, 3- and 4-wire connection.
- Continuous check of vital stored data for safety reasons.

Mounting / installation:

- For DIN form B sensor head mounting.
- **NB:** As Ex barrier we recommend 5104B, 5114B, or 5116B.

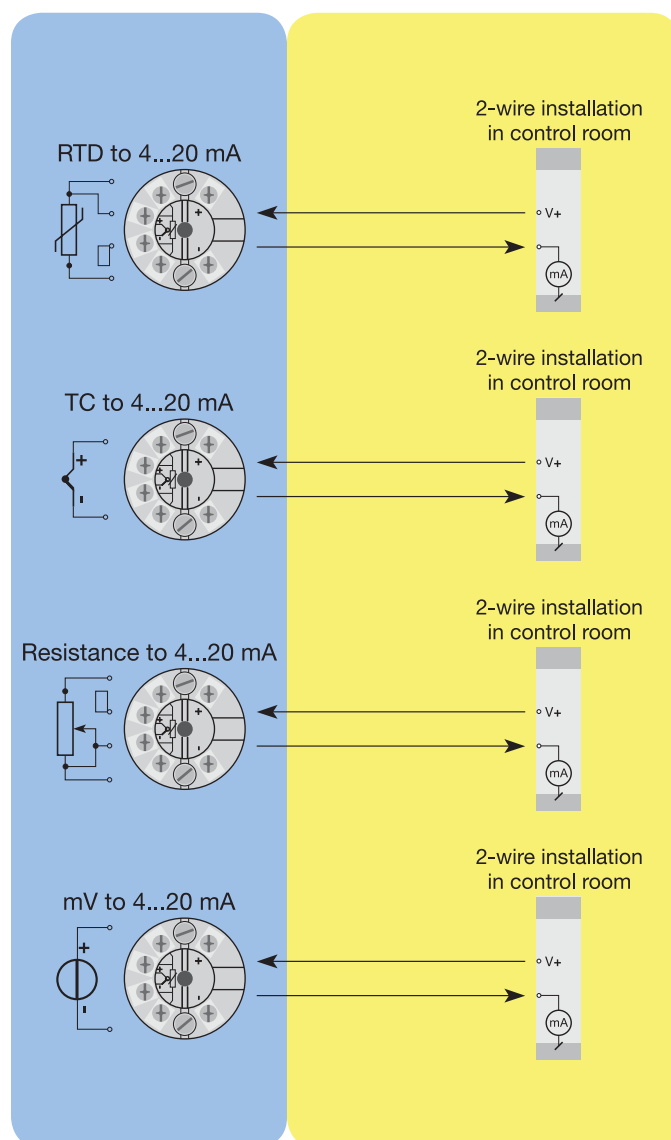

Order: 5331

| Type | Version | Ambient-temperature | Galvanic isolation |
|------|---|---------------------|--------------------|
| 5331 | ATEX : B FM and ATEX : C CSA, FM and ATEX : D | -40°C...+85°C : 3 | 1500 VAC : B |

Connections:

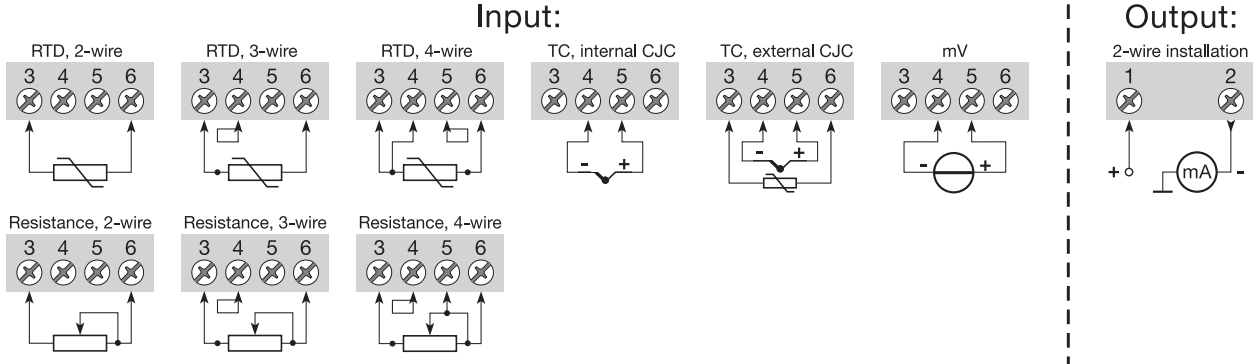

Electrical specifications:

Specifications range:
-40°C to +85°C

Common specifications:

- Supply voltage, DC 7.2...28 V
- Voltage drop 7.2 VDC
- Isolation voltage, test / operation 1.5 kVAC / 50 VAC
- Communications interface Loop Link
- Signal / noise ratio Min. 60 dB
- Signal dynamics, input 20 bit
- Signal dynamics, output 16 bit
- Accuracy, the greater of general and basic values:

| General values | | |
|----------------|-------------------|-------------------------|
| Input type | Absolute accuracy | Temperature coefficient |
| All | ≤ ±0.05% of span | ≤ ±0.01% of span / °C |

| Basic values | | |
|---------------------------------|----------------|-------------------------|
| Input type | Basic accuracy | Temperature coefficient |
| RTD | ≤ ±0.2°C | ≤ ±0.01°C/°C |
| Lin.R | ≤ ±0.1 Ω | ≤ ±10 mΩ/°C |
| Volt | ≤ ±10 μV | ≤ ±1 μV/°C |
| TC type: E, J, K, L, N, T, U | ≤ ±1°C | ≤ ±0.05°C/°C |
| TC type: B, R, S, W3, W5, LR | ≤ ±2°C | ≤ ±0.2°C/°C |

| | |
|---|-----------------|
| EMC immunity influence | < ±0.5% of span |
| Extended EMC immunity: NAMUR NE 21, A criterion, burst | < ±1% of span |

- Vibration IEC 60068-2-6 Test FC
- Lloyd's specification no. 1 4 g / 2...100 Hz
- Humidity < 95% RH (non-cond.)
- Dimensions Ø 44 x 20.2 mm
- Tightness (enclosure / terminal) IP68 / IP00

Electrical specifications, input:

Max. offset 50% of selec. max. value

RTD and linear resistance input:

| RTD type | Min. value | Max. value | Min. span |
|----------|------------|------------|-----------|
| Pt100 | -200°C | +850°C | 25°C |
| Ni100 | -60°C | +250°C | 25°C |
| Lin.R | 0 Ω | 5000 Ω | 30 Ω |

Cable resistance per wire (max.) 5 Ω

Sensor current Nom. 0.2 mA

TC input:

| Type | Min. temperature | Max. temperature | Min. span | Norm |
|------|------------------|------------------|-----------|--------------|
| B | +400°C | +1820°C | 200°C | IEC584 |
| E | -100°C | +1000°C | 50°C | IEC584 |
| J | -100°C | +1200°C | 50°C | IEC584 |
| K | -180°C | +1372°C | 50°C | IEC584 |
| L | -100°C | +900°C | 50°C | DIN 43710 |
| N | -180°C | +1300°C | 100°C | IEC584 |
| R | -50°C | +1760°C | 200°C | IEC584 |
| S | -50°C | +1760°C | 200°C | IEC584 |
| T | -200°C | +400°C | 50°C | IEC584 |
| U | -200°C | +600°C | 75°C | DIN 43710 |
| W3 | 0°C | +2300°C | 200°C | ASTM E988-90 |
| W5 | 0°C | +2300°C | 200°C | ASTM E988-90 |
| LR | -200°C | +800°C | 50°C | GOST 3044-84 |

Cold junction compensation < ±1.0°C

Voltage input:

Measurement range -12...800 mV
Min. span 5 mV

Current output:

Signal range 4...20 mA
Min. signal range 16 mA
Updating time 440 ms
Load resistance ≤ (V_{supply} - 7.2) / 0.023 [Ω]

Sensor error detection:

Programmable 3.5...23 mA

Ex / I.S. data:

- U_i : 28 VDC
- I_j : 120 mA
- P_i : 0.84 W
- L_i : 10 μH
- C_i : 1.0 nF

EEx / I.S. approval:

- DEMKO 99ATEX126962 II 1 G
EEx ia IIC T1...T6
- Max. amb. temperature for T1...T4 ... 85°C
- Max. amb. temperature for T5 and T6 .. 60°C
- Applicable in zone 0, 1 or 2
- FM, applicable in IS, Cl. I, Div. 1, Gr. A, B, C, D
IS, Cl. I, Zone 0, AEx ia IIC
- Entity, FM Installation Drawing No. ... 5300Q502
- CSA, applicable in IS, Cl. I, Div. 1, Gr. A, B, C, D
Ex ia IIC
IS, Cl. I, Zone 0, AEx ia IIC
- Installation Drawing No. 533XQC03

Marine approval:

Det Norske Veritas, Ships & Offshore. Stand. for Certification 2.4

Observed authority requirements: Standard:

- EMC 2004/108/EC
- Emission and immunity EN 61326
- ATEX 94/9/EC EN 50014 and EN 50020
- FM, ASCN 3600, 3611, 3610
- CSA, CAN / CSA C22.2 No. 157,
E60079-11, UL 913

Of span = Of the presently selected range