

- **SEALS A SINGLE ELECTRODE OR EQUIVALENT DIAMETER TUBE OR PROBE**
- **FOR APPLICATIONS IN GAS OR NON-CONDUCTIVE LIQUIDS**
- **PRESSURE:**
Vacuum to 690 bar
- **TEMPERATURE:**
-185°C to +870°C
- **VOLTAGE:** To 8,000Vdc
- **CURRENT:** To 400A
- **STAINLESS STEEL REUSABLE FITTING**
- **REPLACEABLE 'SOFT' SEALANT (EG) OR COMBINED, TEFLON INSULATOR/SEALANT (EGT)**

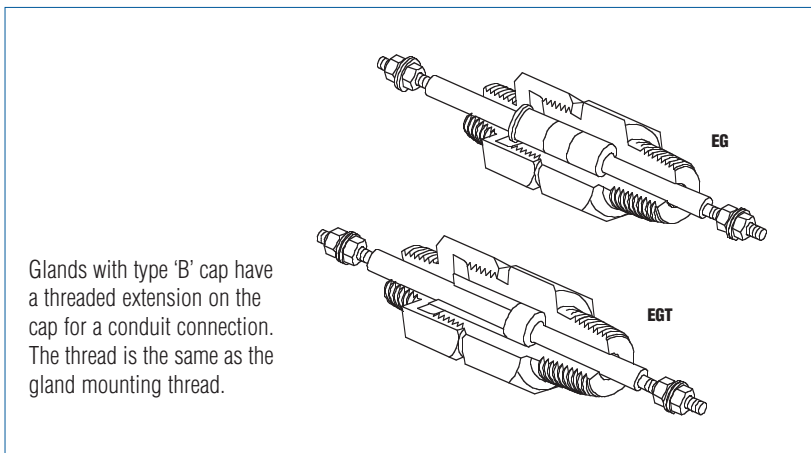

EG and EGT glands are pressure / vacuum sealing assemblies with single integral electrodes. These glands are used to provide electrical feedthroughs for high-power and high-voltage supply connections in a range of electrode sizes. Standard glands are supplied with copper, nickel or stainless steel electrodes pre-installed in the gland that is torqued ready for installation. EG & EGT glands can also be supplied untorqued and without electrodes.

Conax Buffalo sealing assemblies can be specified for use in a range of temperature, pressure and environmental situations. A sealant may be chosen for EG glands that is suitable for the application. EGT glands are only available with a single-piece, Teflon insulator/sealant. Replacement sealants, insulators and electrodes are available to enable repeated use of fittings.

EG glands employ soft sealants and have ceramic insulators, they are rated 2,000Vdc @ 400A max.

EGT glands have a Teflon, single-piece, combined sealant and insulator and are rated 8,000Vdc @ 200A max..

*Applications for EG and EGT glands include :
Power feedthroughs for vacuum furnaces, autoclaves, equipment enclosures, transformers and environmental chambers, also high-voltage feedthroughs to reactor vessels.*

EG & EGT gland bodies, followers and caps are manufactured from Stainless Steel AISI grades 316L (W.-Nr. 1.4404) and 303 (1.4305). Other materials may be specified. EG insulators are Alumina.

SEALANT SELECTION GUIDE

Sealant (Sealant Code)	Temperature range	Pressure range @ 20°C
Neoprene (N) [EG]	-40°C to +93°C	Vacuum to 355 bar
Viton (V) [EG]	-20°C to +232°C	Vacuum to 220 bar
Teflon (T) (EG & EGT)	-185°C to +232°C	Vacuum to 345 bar [EG] 170 bar [EGT]
Lava (L) [EG]	-185°C to +870°C	1 bar (0.1MPa) to 550 bar

SPECIFICATIONS, ORDERING INFORMATION

Current Rating (A) Electrode (See Note 2)			Gland mounting thread (NPT)	Gland Description [Order Code] (See note 1)	Pressure rating by sealant (bar) (See note 3)			
CU	NI	SS			Neoprene (N)	Viton (V)	Teflon (T)	Lava (L)
EG glands (Rated operating voltage 2kV max.)								
20	8	3	1/8"	EG-093-*- η -**	220	220	220	275
40	16	6	1/4"	EG-125-*- η -**	355	220	345	550
60	24	9	1/4"	EG-187-*- η -**	170	220	170	330
95	39	15	1/2"	EG-250-*- η -**	80	80	135	380
125	51	20	1/2"	EG-312-*- η -**	110	80	220	380
160	65	24	3/4"	EG-375-*- η -**	40	55	170	275
200	81	30	3/4"	EG-500-*- η -**	40	40	110	105
400	163	60	1 1/2"	EG-750-*- η -**	-	-	125	-
EGT glands (Rated operating voltage 8kV max. except EGT-093 4kV max.)								
20	8	3	1/8"	EGT-093-*- η	-	-	170	-
40	16	6	1/4"	EGT-125-*- η	-	-	80	-
60	24	9	1/2"	EGT-187-*- η	-	-	110	-
95	39	15	1/2"	EGT-250-*- η	-	-	80	-
160	65	24	3/4"	EGT-375-*- η	-	-	40	-
200	81	30	3/4"	EGT-500-*- η	-	-	40	-
400	163	60	1"	EGT-750-*- η	-	-	40	-

DIMENSIONS

Size of gland	Gland mounting thread (NPT)	Electrode (Conductor)		Body Hex size (in.)	Cap Hex size (in.)	Length of gland with type A cap Dim. A (mm)	Length of gland with type B cap Dim. B (mm)
		Dia. (mm)	Length (mm)				
EG-093	1/8"	2.36	89	1/2	9/16	34.93	44.45
EGT-093			81		1/2	30.16	39.69
EG & EGT-125	1/4"	3.05	127	3/4	3/4	52.39	66.68
EG-187							
EGT-187	1/2"	6.22	165	1	1	65.09	87.31
EG & EGT-250							
EG-312	3/4"	9.40	216	1 1/4	1 1/2	79.38	98.43
EGT-375						73.03	92.08
EG-500						79.38	98.43
EGT-500						73.03	92.08
EG-750	1 1/2"	18.92	394	2 1/2 (63.5mm) across flats	(See Note 5)	139.70	-
EGT-750	1"	18.92	394	1 3/4	2	88.90	114.30

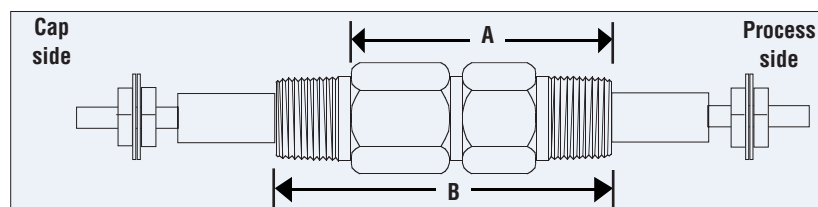

NOTES

Note 1:

The Gland Description [Order Code] shown in the table, is completed by selecting the type of cap required - A or B is inserted at *.

The code for the electrode required is inserted at η as follows:

CU for Copper (Max. temp. 380°C).

NI for Nickel (Max. temp. 600°C)

SS for Stainless Steel (Max. temp. 870°C)

XX without an electrode

For EG glands the code letter for the sealant selected is inserted at **.

EG example: EG-125-B-NI-L describes an EG-125 size gland (1/4" NPT mounting thread) with a nickel electrode rated 16A max., with type B cap and Lava sealant.

EGT example: EGT-250-A-CU describes an EGT-250 size gland (1/2" NPT mounting thread) with a copper electrode rated 95A max., and type A cap.

Replacement Sealant Order Code

Examples: RS-EG-125-L
RS-EGT-250

Replacement Packing Set Order Code for EG glands (Sealant and two ceramic insulators)

Example: RPS-EG-125-L

Replacement Insulator Order Code for EG glands (Single insulator)

Example: RI-EG-125

Replacement Electrode Order Code

Examples: RE-EG-125-NI
RE-EGT-250-CU

Note 2:

Electrodes have tapped threads and are fitted with two nuts and washers at each end for ring tongue or lug-type cable terminals.

Electrodes may be substituted with tubes, probes or sensors of equivalent diameter $\pm 0.127\text{mm}$ ($\pm 0.005"$) *Caution: May affect pressure ratings.*

Note 3:

All pressure and vacuum ratings are determined at 20°C with a stainless steel rod as the element.

Note 4:

Where no value is shown in the tables the option is not available.

Note 5:

EG-750 gland assemblies have a flange-design cap with qty. 6 x hex. head cap screws. Flange dia. 82.55mm. Type B cap not available.



thermo-electra

measurement and control technics

P.O. box 73
2640 AB Pijnacker, The Netherlands
Phone: +31 15 362 12 00
Fax: +31 15 369 40 82
E-mail: mail@thermo.nl
Internet: www.thermo-electra.com