



ME 1062 Thermocouple with Stainless Steel Armoured Lead Wire

Sheath

Construction	Minderal insulated
Material	SS 316 - (Wst 1.4401)
Insulation	MgO
Diameter "D"	Customer to specify
Length "L"	Customer to specify

Lead wire

Teflon insulated
flexible thermocouple wire (E 55)
with stainless-steel flexible
hose 240 °C

Lead wire Length "K"

Customer to specify

Element

Calibration	K, T, J, E, N, U or L
For duplex	KK, TT, JJ, EE, NN, UU or LL
Accuracy	According IEC 584-1 / DIN 43710
Hot junction	Insulated
Testing	Tested at 500 Volt/20 °C
Insulation resistance	Minimum 100 M ohm
Available diameter	(0.25 - 0.5 - 1.0)* 1.5 - 2.0 - 3.0 - 4.5 6.0 and 8.0 mm. Other diameters possible * single only

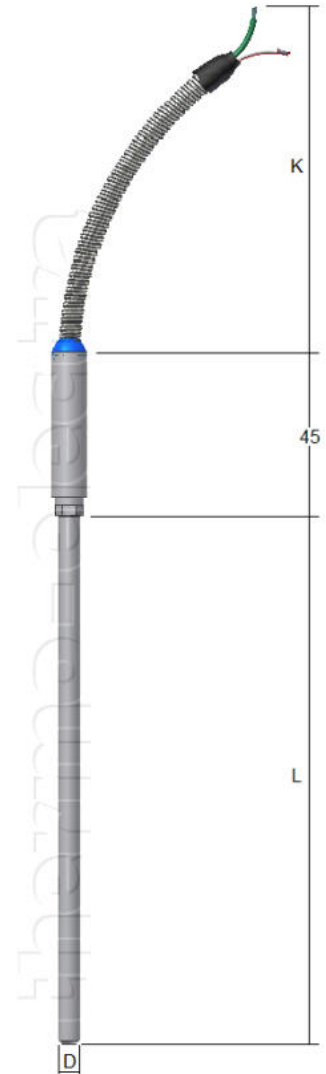

Ordering code

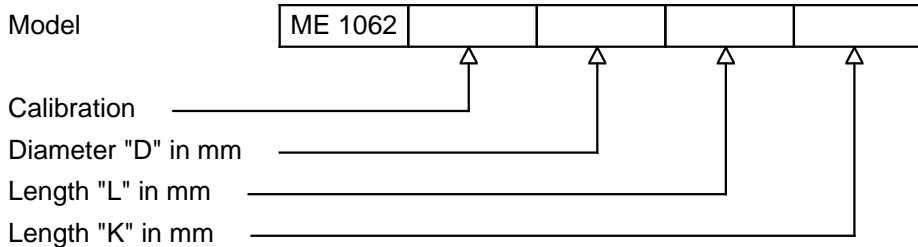

H1-1 Rev.0 7/07



thermo-electra
measurement and control technics

PO BOX 73
2640 AB Pijnacker
The Netherlands

Phone +31 (0)15 - 3621200
Fax +31 (0)15 - 3694082
Email sales@thermo.nl
Internet <http://www.thermo-electra.com>