



DWK 6022 Vibration Proof Thermocouple

Design

Applications Designed for use on combustion engines

Protection tube

Construction Closed-end tube
Material SS 316 - (Wst 1.4401)
Insertion length "L" Customer to specify, standard 150 mm
Diameter 12 mm conical
Process connection 1 / 2" BSP steel compression gland

Lead wire

Heat and oil resistant, armoured thermocouple extension cable 250 °C

Lead wire length "K"

Customer to specify, standard 1000 mm

Element

Sensor K, J or L Thermocouple, Customer to specify
Accuracy According IEC 584-1
Hot junction Insulated
Testing Tested at 500 Volt / 20 °C
Insulation Minimum 100 M ohm
Design Vibrationproof

Temperature

800 °C maximum

Ordering code

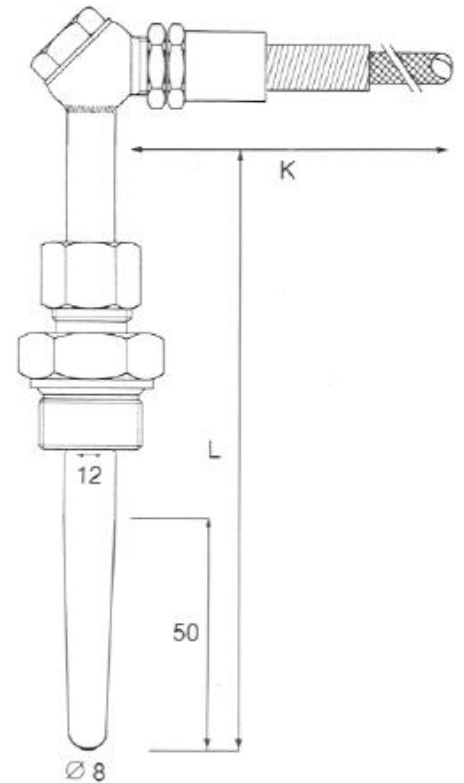
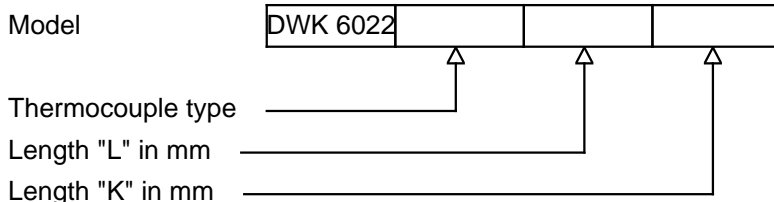

H6-1 Rev. 07/07



thermo-electra
measurement and control technics

PO BOX 73
2640 AB Pijnacker
The Netherlands

Phone +31 (0)15 - 3621200
Fax +31 (0)15 - 3694082
Email sales@thermo.nl
Internet <http://www.thermo-electra.com>